

## BATHSELECT COMMERCIAL STAINLESS STEEL AUTOMATIC CHROME SOAP DISPENSER SPECS

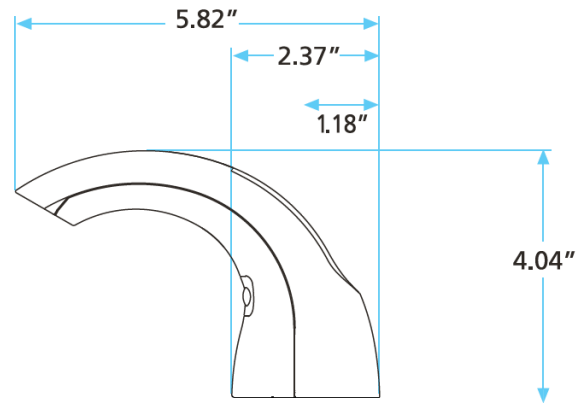

### Specs:

- Product Type: Commercial
- Main Construction Material: Brass
- Mount Type: Deck
- Handle Type: Infra-Red
- Power: Battery box for 6 x 1.5 V D alkaline batteries
- Power Source: 12 V transformer
- Number of Tap Holes: 1
- Valve/Cartridge Type: Solenoid Valve
- Sensing Range: Adjustable with optional remote control
- Adaptable swivel motor
- housing design allows: 360-degree rotation
- Soap Bottle Capacity: 1500 and 2300 mL refills
- Viscosity of Liquid Soap: 0.5ML to 1.5ML, adjustable
- Extended battery lifet: 45,000 uses

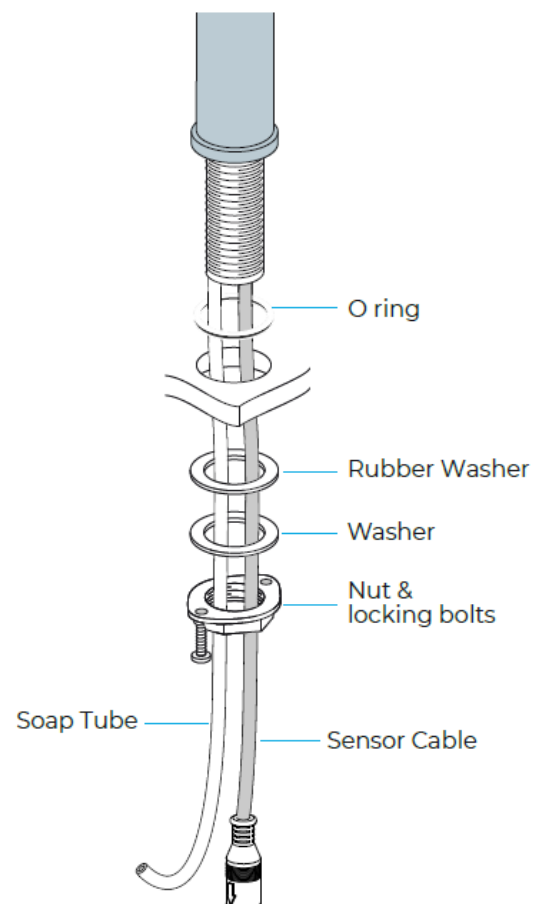

[Visit Product Page](#)